

### Specification Sheet 9508-0\*

Issue Date: January 2006

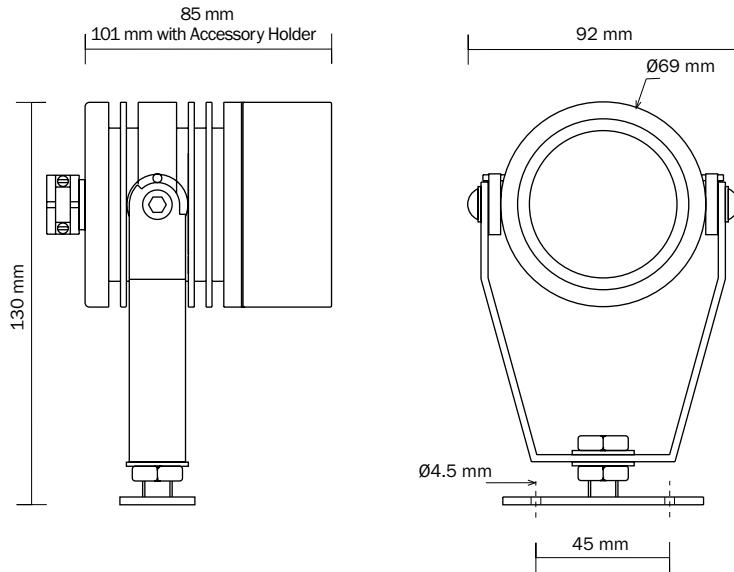

**Product Name:**

Minor 1

**Description:**

Exterior M16 Remote Low Voltage Surface Mounted Spotlight

**Part Number:**

9508-0\*

\* = Finish Code

**TECHNICAL DETAILS**

**Lamp:** QRCB51 / HRGI-GU5.3-51

**Lamp Holder:** Bi-Pin GX5.3

**Supply Voltage:** 12V

**Lamp Voltage:** 12V

**Max Lamp Wattage:** 50W

**Weight:** Aluminium 0.5kg (excluding cable)

**Weight:** Brass 1.85kg (excluding cable)

**Glass Size:** Ø55mm

**Supplied Cable:** 2.5m 2-Core 1.5mm<sup>2</sup> Silicone

**Housing:**

Anodised aluminium housing with a PTFE painted finish or solid brass with specified finish

**Transformer:**

Requires a remote SELV transformer to EN60742 or BS3535

For more information please refer to transformer specification sheet TRE001

**NB** Light fittings become hot during use – please exercise appropriate caution.

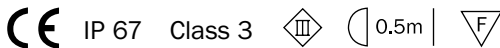

**Sample Lamp Data for BLV 12V 50W MR16 Tungsten Halogen 51mm Dichroic Reflector**

Beam Detail	LP Code	Peak Illumination / Lux				AV Lamp Life / hours	Colour Temperature / °K
		1.0m	2.0m	3.0m	4.0m		
12° Spot	105-018	11,000	2,750	1,222	688	4,000	3,000
24° Flood	105-019	2,800	700	311	175	4,000	3,000
36° Wide Flood	105-020	1,580	395	176	99	4,000	3,000
60° Very Wide Flood	105-021	850	213	94	53	4,000	3,000
24° Flood	105-062	2,200	550	244	138	10,000	3,100
36° Wide Flood	105-063	1,500	375	167	94	10,000	3,100

Please note that alternative beam angles and lamp wattage may be available. Please refer to lamp specification sheet LS002 for more details.

**FINISHES AVAILABLE**

**White (RAL 9016)**  
Part Number 9508-01

**Black (RAL 9011)**  
Part Number 9508-02

**Specified BS/RAL**  
Part Number 9508-03 + BS/RAL No

**Metal Finish**  
Part Number 9508-05 + Req Finish

**Solid Brass**  
Part Number 9508-08

**FACTORY FITTED OPTIONS**

Extra cable per m - state length 247-0081/\*\*m  
Long Snoot 95084-0\*

**NB**  
Max length of cable  
20W - 12m  
35W - 7m  
50W - 5m

**ACCESSORIES / SPARES**

Long Snoot for Accessories	247-0201-*
C Spring	247-0206
Replacement Standard Snoot	247-0207-*
Colour Glass ◇	247-0210-***
(See sheet CG001)	
Spread Lens Ribbed ◇	247-0211
Colour Dichroic Glass ◇	247-0215-***
(See sheet CDG001)	
Light Frost ◇	247-0216
Medium Frost ◇	247-0217
Heavy Frost ◇	247-0218
5mm Louvre ◇	247-0221-2
Half Shield Cowl	247-0227-*
Full Tube Cowl	247-0228-*
Tree Strap Remote	247-0240-2
Ground Spike Remote 200mm	247-0141-*
Ground Spike Remote 500mm	247-0142-*
IP66 Connection Box	247-0080
Replacement Lamp Holder	247-0289

◇ Indicates Long Snoot and C Spring is required

**SPECIFICATION EXAMPLE**

Minor 1, Black Finish with extra 2m cable, Light Frost Lens and 12V 50W 24° Lamp:

Fitting Code (with finish) + Option Code + Accessory Codes + Lamp Code

**9508-02 + 247-0081/2m + 247-0206 + 247-0216 + 247-0201+ 105-019**

Lightscape Projects is a division of the Light Projects Group of companies, London. **Product Improvements** In pursuance of the Light Projects Group policy of continuing product improvement, the products and product specifications included in this publication are liable to be modified without notice. **Trademarks** Unless otherwise indicated, the trademarks and tradenames in this publication are registered, or unregistered, industrial property rights of Light Projects Limited. **Patents** The fitting in this publication may be covered by Patents, Patent Applications and/or Design Registrations. Designed to conform to BS EN 60598. This specification sheet supersedes all previous. Please notify Light Projects Limited of any inaccuracies immediately. E&OE.

**Light Projects** 23 Jacob St London SE1 2BG Tel +44 (0)20 7231 8282 Fax +44 (0)20 7237 4342  
Website www.lightprojects.co.uk Email info@lightprojects.co.uk