

Specification Sheet 2516-0*

Issue Date: August 2008

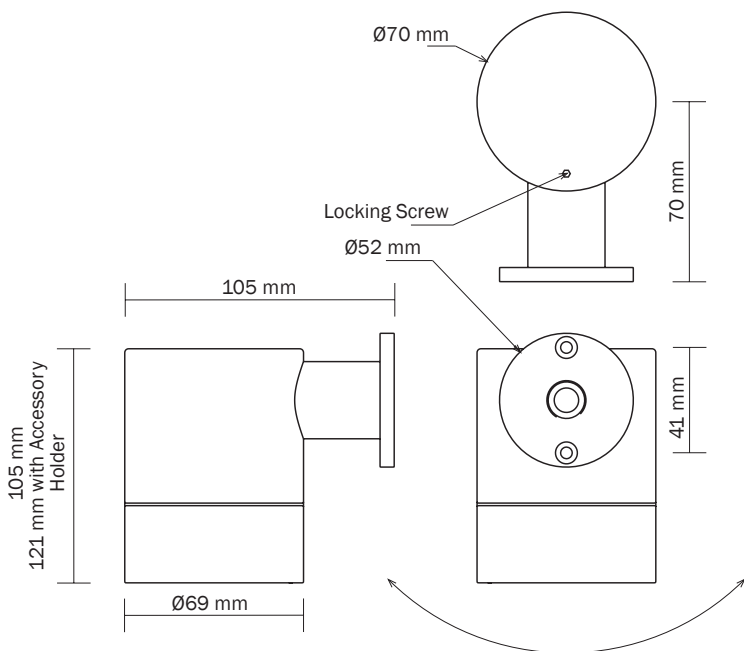

Product Name:

Minor Wall

Description:

Exterior M16 Remote Low Voltage Surface Mounted Spotlight

Part Number:

2516-0*

* = Finish Code

TECHNICAL DETAILS

Lamp: QRCB51 / HRGI-GU5.3-51

Lamp Holder: Bi-Pin GX5.3

Supply Voltage: 12V

Lamp Voltage: 12V

Max Lamp Wattage: 50W

Weight: Aluminium 0.8kg (excluding cable)

Weight: Brass 2.3kg (excluding cable)

Glass Size: Ø55mm

Supplied Cable: 2.5m 2-Core 1.5mm² Silicone

Housing:

Anodised aluminium housing with a PTFE painted finish or solid brass with specified finish

Transformer:

Requires a remote SELV transformer to EN60742 or BS3535

For more information please refer to transformer specification sheet TRE001

NB Light fittings become hot during use – please exercise appropriate caution.

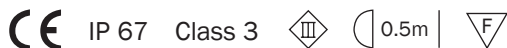

Sample Lamp Data for BLV 12V 50W MR16 Tungsten Halogen [51mm Dichroic Reflector]

| Beam Detail | LP Code | Peak Illumination / Lux | | | | AV Lamp Life / hours | Colour Temperature / °K |
|---------------------|---------|-------------------------|-------|-------|------|----------------------|-------------------------|
| | | 1.0m | 2.0m | 3.0m | 4.0m | | |
| 12° Spot | 105-018 | 11,000 | 2,750 | 1,222 | 688 | 4,000 | 3,000 |
| 24° Flood | 105-019 | 2,800 | 700 | 311 | 175 | 4,000 | 3,000 |
| 36° Wide Flood | 105-020 | 1,580 | 395 | 176 | 99 | 4,000 | 3,000 |
| 60° Very Wide Flood | 105-021 | 850 | 213 | 94 | 53 | 4,000 | 3,000 |
| 24° Flood | 105-062 | 2,200 | 550 | 244 | 138 | 10,000 | 3,100 |
| 36° Wide Flood | 105-063 | 1,500 | 375 | 167 | 94 | 10,000 | 3,100 |

Please note that alternative beam angles and lamp wattage may be available. Please refer to lamp specification sheet LS002 for more details.

FINISHES AVAILABLE

White (RAL 9016)
Part Number 2516-01

Black (RAL 9011)
Part Number 2516-02

Specified BS/RAL
Part Number 2516-03 + BS/RAL No

Metal Finish
Part Number 2516-05 + Req Finish

Solid Brass
Part Number 2516-08

FACTORY FITTED OPTIONS

Extra cable per m - state length 247-0081/**m
Long Snoot 95084-0*

NB
Max length of cable 20W - 12m
35W - 7m
50W - 5m

ACCESSORIES / SPARES

| | |
|----------------------------|--------------|
| Long Snoot for Accessories | 247-0201-* |
| C Spring | 247-0206 |
| Replacement Standard Snoot | 247-0207-* |
| Colour Glass ◊ | 247-0210-*** |
| (See sheet CG001) | |
| Spread Lens Ribbed ◊ | 247-0211 |
| Colour Dichroic Glass ◊ | 247-0215-*** |
| (See sheet CDG001) | |
| Light Frost ◊ | 247-0216 |
| Medium Frost ◊ | 247-0217 |
| Heavy Frost ◊ | 247-0218 |
| 5mm Louvre ◊ | 247-0221-2 |
| IP66 Connection Box | 247-0080 |
| Replacement Lamp Holder | 247-0289 |

◊ Indicates Long Snoot and C Spring is required

SPECIFICATION EXAMPLE

Minor Wall, Black Finish with extra 2m cable, Light Frost Lens and 12V 50W 24° Lamp:

Fitting Code (with finish) + Option Code + Accessory Codes + Lamp Code

2516-02 + 247-0081/2m + 247-0206 + 247-0216 + 247-0201+ 105-019

Lightscape Projects is a division of the Light Projects Group of companies, London. **Product Improvements** In pursuance of the Light Projects Group policy of continuing product improvement, the products and product specifications included in this publication are liable to be modified without notice. **Trademarks** Unless otherwise indicated, the trademarks and tradenames in this publication are registered, or unregistered, industrial property rights of Light Projects Limited. **Patents** The fitting in this publication may be covered by Patents, Patent Applications and/or Design Registrations. Designed to conform to BS EN 60598. This specification sheet supersedes all previous. Please notify Light Projects Limited of any inaccuracies immediately. E&OE.

Light Projects 23 Jacob St London SE1 2BG Tel +44 (0)20 7231 8282 Fax +44 (0)20 7237 4342
Website www.lightprojects.co.uk Email info@lightprojects.co.uk